

Data Integration and Analysis

12 Stream Processing

Matthias Boehm

Graz University of Technology, Austria
Computer Science and Biomedical Engineering
Institute of Interactive Systems and Data Science
BMVIT endowed chair for Data Management

Announcements/Org

- **#1 Video Recording**

- Link in **TeachCenter** & **TUbe** (lectures will be public)



- **#2 DIA Projects**

- **13 Projects** selected (various topics)
- **3 Exercises** selected (distributed data deduplication)
- SystemDS: apps into `./scripts/staging/<your_project>`

If problems,
**please ask for
help**

- **#3 Exam**

- **Feb 3, 1pm – Feb 5, 2pm**, remote exam possible
- Oral exam, **45min slots**, first-come, first-serve
- <https://doodle.com/poll/ikzsffek2vhd85q4>

- **#4 Course Evaluation**

- Evaluation time frame: **Jan 14 – Feb 14** → feedback

2/21

Announcements/Org, cont.

- **#5 Know-Center Data Science Challenge**

- <https://www.know-center.tugraz.at/en/registration-data-science-challenge-2020-now-open/>
- Working time until **Feb 3**
- Awards at AI-Know **Feb 10** (2,000; 1,200; 800 EUR)



- **#6 Mindfire Data Science Challenge**

- https://mindfire-quests.webflow.io/swiss-re-quest?fbclid=IwAR3RQbskHuFsLarQYsEfko4m7hEYN7Rwj1U9jeBX6r7Dm_3DfPezcv4KwCE
- **Swiss Re Sustainable Travel Quest** (CO2 emissions)
- Working time until **May 1**
- 25,000 CHF (23,343 EUR)



MINDFIRE



Agenda

- Data Stream Processing
- Distributed Stream Processing
- Data Stream Mining

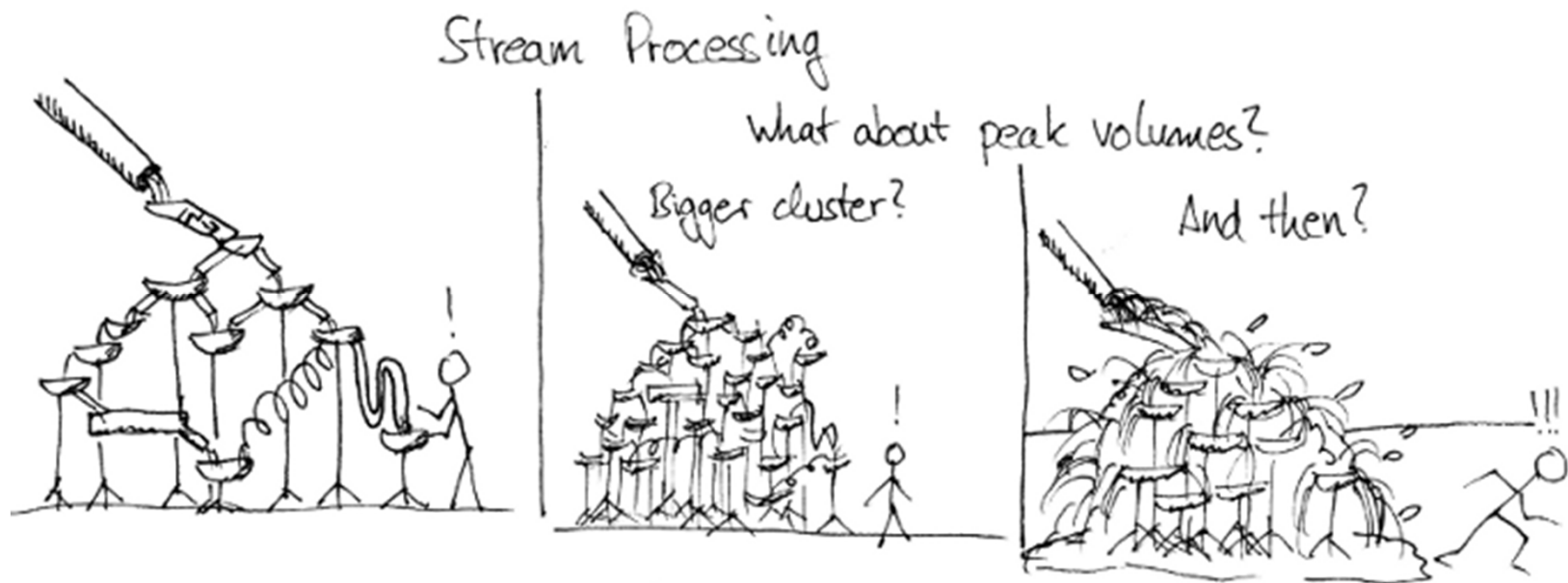

Data Stream Processing

Stream Processing Terminology

Ubiquitous Data Streams

- **Event and message streams** (e.g., click stream, twitter, etc)
- Sensor networks, IoT, and monitoring (traffic, env, networks)



Stream Processing Architecture

- **Infinite input streams**, often with window semantics
- Continuous (aka standing) queries

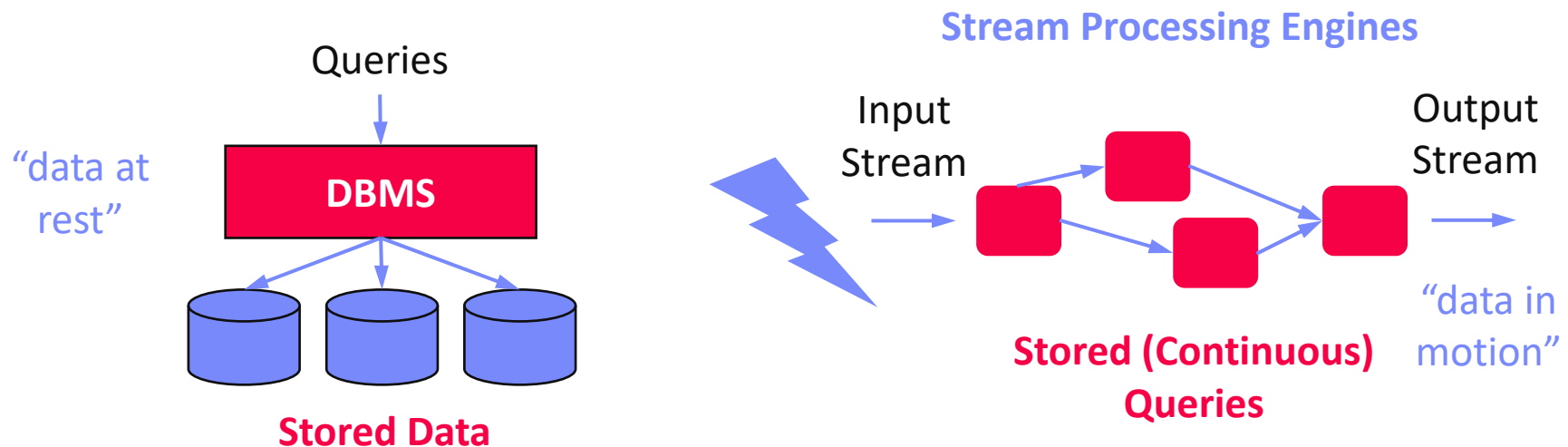

Stream Processing Terminology, cont.

■ Use Cases

- **Monitoring and alerting** (notifications on events / patterns)
- **Real-time reporting** (aggregate statistics for dashboards)
- **Real-time ETL** and event-driven data updates
- Real-time decision making (fraud detection)
- Data stream mining (summary statistics w/ limited memory)

Continuously
active

■ Data Stream

- Unbounded stream of data tuples $S = (s_1, s_2, \dots)$ with $s_i = (t_i, d_i)$
- See [DM 10 NoSQL Systems](#) (time series)

■ Real-time Latency Requirements

- **Real-time**: guaranteed task **completion by a given deadline** (30 fps)
- **Near Real-time**: few milliseconds to seconds
- In practice, used with much weaker meaning

History of Stream Processing Systems

■ 2000s

- **Data stream management systems** (DSMS, mostly academic prototypes): **STREAM** (Stanford'01), **Aurora** (Brown/MIT/Brandeis'02) → **Borealis** ('05), **NiagaraCQ** (Wisconsin), **TelegraphCQ** (Berkeley'03), and many others
→ but mostly unsuccessful in industry/practice
- **Message-oriented middleware** and **Enterprise Application Integration** (EAI): IBM **Message Broker**, SAP **eXchange Infra.**, MS **Biztalk Server**, **TransConnect**

■ 2010s

- **Distributed stream processing engines**, and “unified” batch/stream processing
- **Proprietary systems**: Google Cloud Dataflow, MS StreamInsight / Azure Stream Analytics, IBM InfoSphere Streams / Streaming Analytics, AWS Kinesis
- **Open-source systems**: **Apache Spark Streaming** (Databricks), **Apache Flink** (Data Artisans), **Apache Kafka** (Confluent), **Apache Storm**



System Architecture – Native Streaming

Basic System Architecture

- Data flow graphs (potentially w/ multiple consumers)
- Nodes:** asynchronous ops (w/ state) (e.g., separate threads)
- Edges:** data dependencies (tuple/message streams)
- Push model:** data production controlled by source

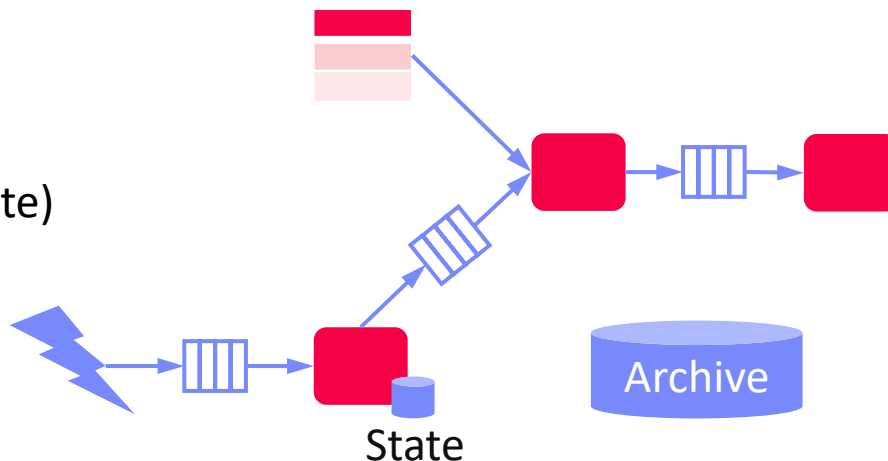

Operator Model

- Read from input queue
- Write to potentially many output queues
- Example Selection

$\sigma_{A=7}$

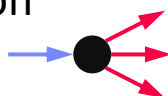

```
while( !stopped ) {
    r = in.dequeue(); // blocking
    if( pred(r.A) ) // A==7
        for( Queue o : out )
            o.enqueue(r); // blocking
}
```

System Architecture – Sharing

Multi-Query Optimization

- Given **set of continuous queries** (deployed), compile minimal DAG w/o redundancy (see [DM 08 Physical Design MV](#)) → **subexpression elimination**

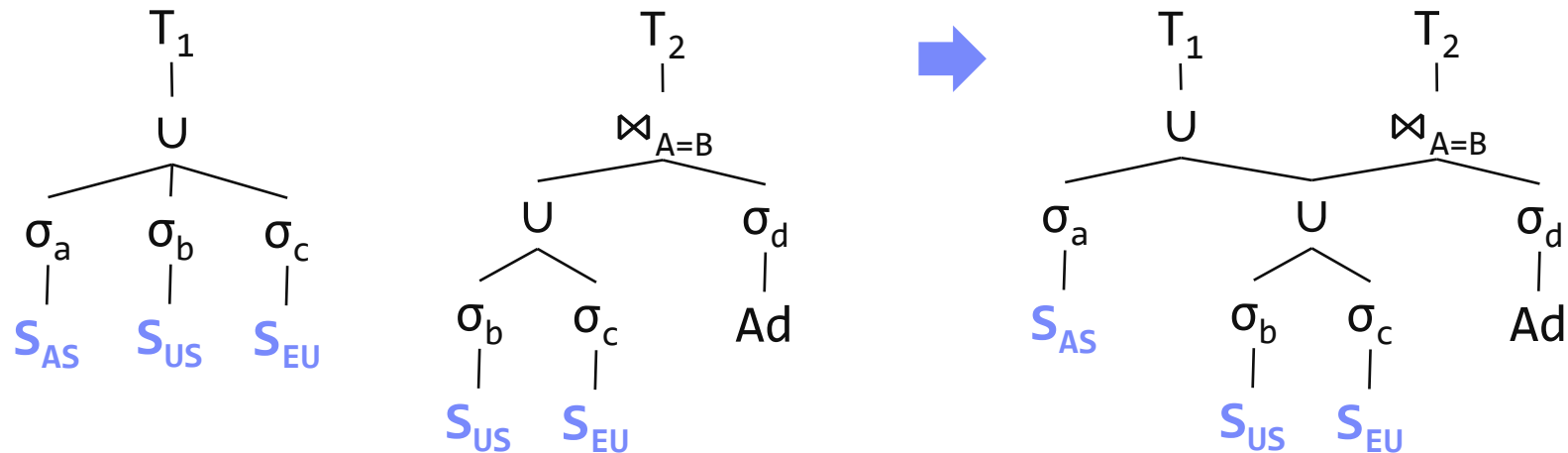

Operator and Queue Sharing

- Operator sharing:** complex ops w/ multiple predicates for adaptive reordering
- Queue sharing:** avoid duplicates in output queues via masks

System Architecture – Handling Overload

#1 Back Pressure

- Graceful handling of overload w/o data loss
- **Slow down sources**
- E.g., blocking queues

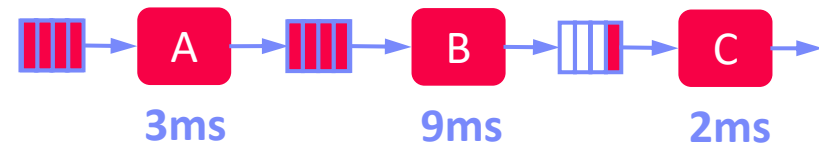

Self-adjusting operator scheduling
Pipeline runs at rate of slowest op

#2 Load Shedding

- #1 **Random-sampling**-based load shedding
- #2 **Relevance-based** load shedding
- #3 **Summary-based** load shedding (synopses)
- Given SLA, select queries and shedding placement that minimize error and satisfy constraints

[Nesime Tatbul et al: Load Shedding in a Data Stream Manager. **VLDB 2003**]



#3 Distributed Stream Processing (see course DIA)

- Data flow partitioning (distribute the query)
- Key range partitioning (distribute the data stream)

Time (Event, System, Processing)

■ Event Time

- Real time when the event/
data item was created

■ Ingestion Time

- System time when the
data item was received

■ Processing Time

- System time when the
data item is processed

■ In Practice

- Delayed and unordered data items
- Use of heuristics (e.g., **water marks = delay threshold**)
- Use of more complex triggers (**speculative and late results**)

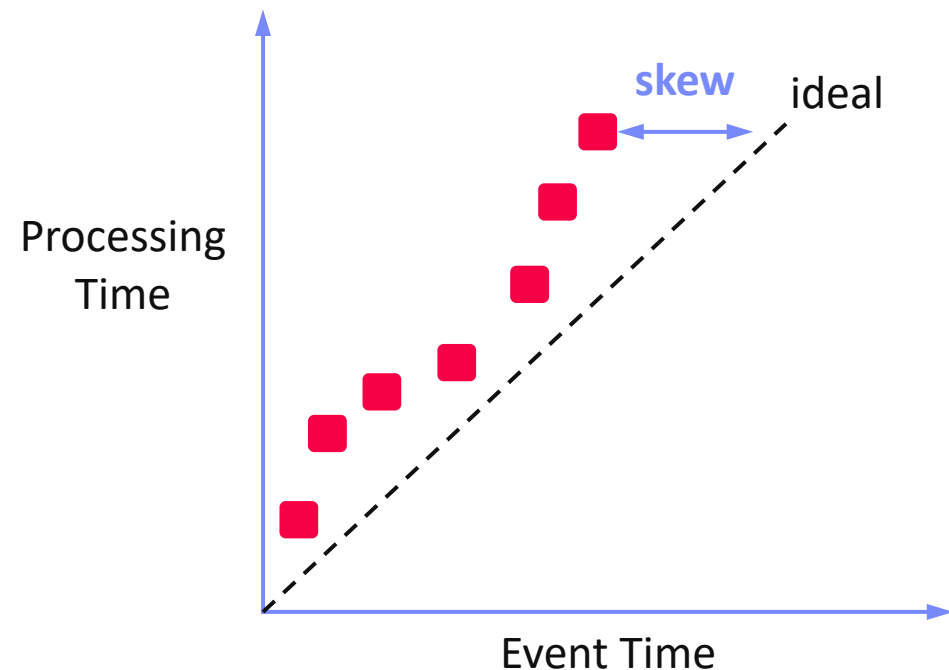

Durability and Consistency Guarantees

- **#1 At Most Once**
 - “Send and forget”, ensure data is never counted twice
 - Might cause data loss on failures
- **#2 At Least Once**
 - “Store and forward” or acknowledgements from receiver, replay stream from a checkpoint on failures
 - Might create incorrect state (processed multiple times)
- **#3 Exactly Once**
 - “Store and forward” w/ guarantees regarding state updates and sent msgs
 - Often via dedicated transaction mechanisms

03 Message-oriented
Middleware, EAI, and
Replication



Window Semantics

Windowing Approach

- Many operations like joins/aggregation **undefined over unbounded streams**
- Compute operations over windows of **(a) time** or **(b) elements counts**

#1 Tumbling Window

- Every data item is only part of a single window
- Aka Jumping window

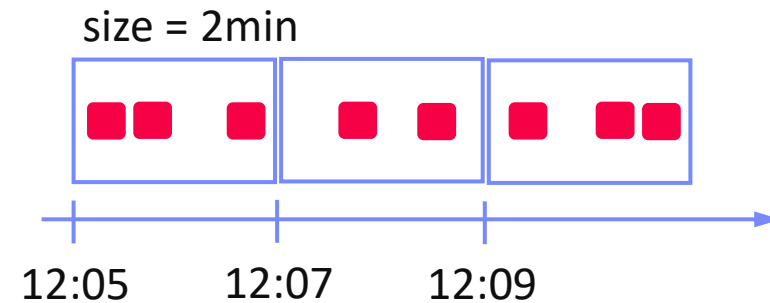

#2 Sliding Window

- Time- or tuple-based sliding windows
- Insert new and expire old data items

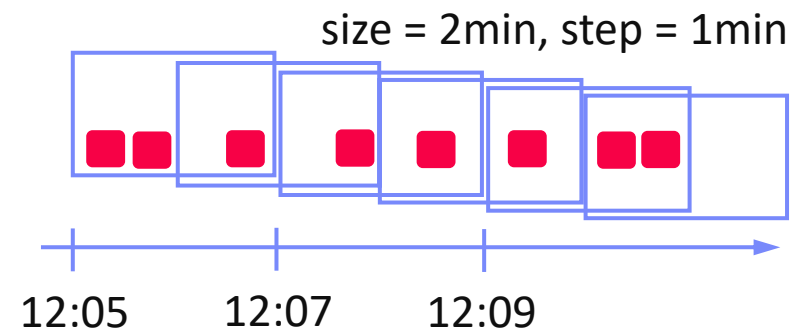

Stream Joins

Basic Stream Join

- **Tumbling window:**
use classic join methods
- **Sliding window** (symmetric for both R and S)
 - Applies to arbitrary join pred
 - See [DM 08 Query Processing \(NLJ\)](#)

For each new r in R:

1. **Scan** window of stream S to find match tuples
2. **Insert** new r into window of stream R
3. **Invalidate** expired tuples in window of stream R

Excursus: How Soccer Players Would do Stream Joins

- **Handshake-join** w/ 2-phase forwarding

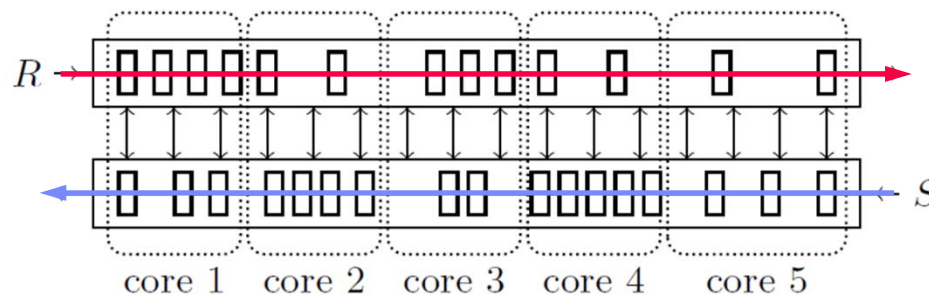

[Jens Teubner, René Müller: How soccer players would do stream joins. **SIGMOD 2011**]



Stream Joins, cont.

[Zachary G. Ives, Daniela Florescu, Marc Friedman, Alon Y. Levy, Daniel S. Weld: An Adaptive Query Execution System for Data Integration. **SIGMOD 1999**]



Double-Pipelined Hash Join

- Join of bounded streams (or unbounded w/ invalidation)
- Equi join predicate**, **symmetric and non-blocking**
- For every incoming tuple (e.g. left): probe (right)+emit, and build (left)

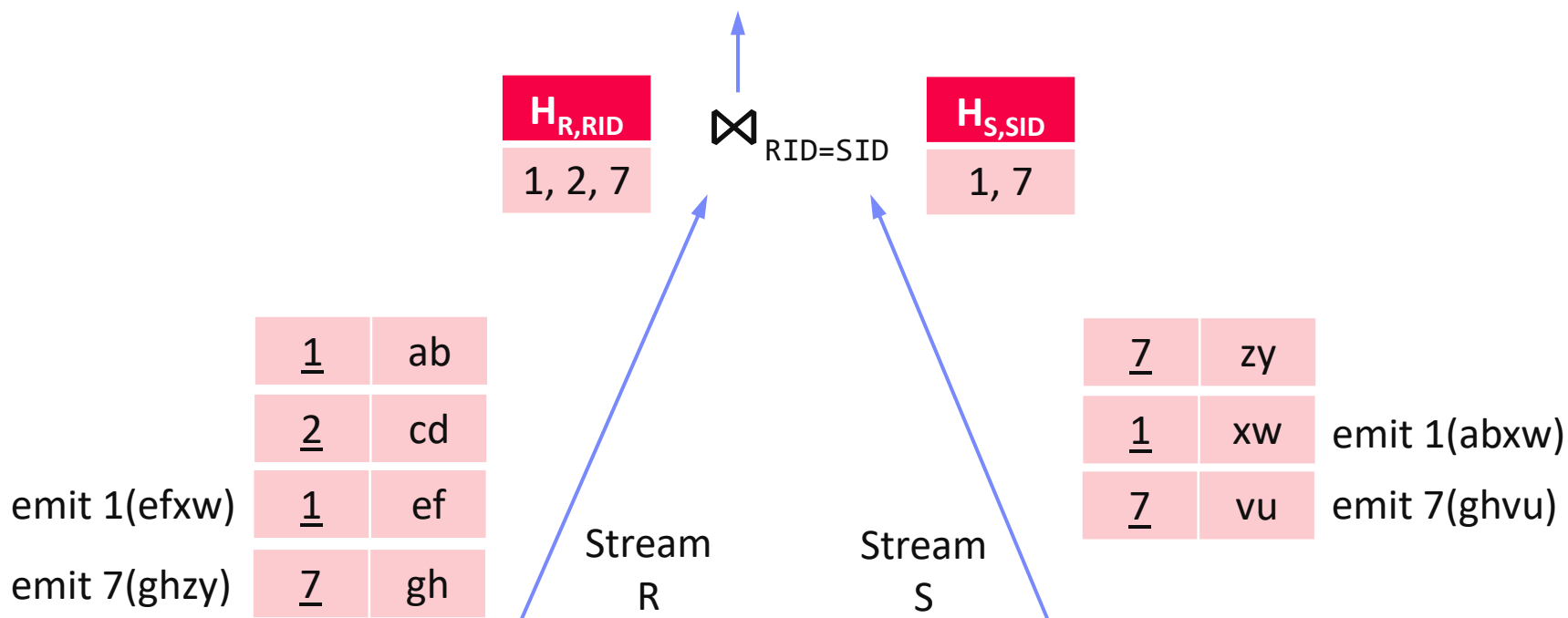

Excursus: Example Twitter Heron

[Credit: Karthik Ramasamy]

■ Motivation

- Heavy use of Apache Storm at Twitter
- Issues: **debugging**, **performance**, shared **cluster resources**, back pressure mechanism

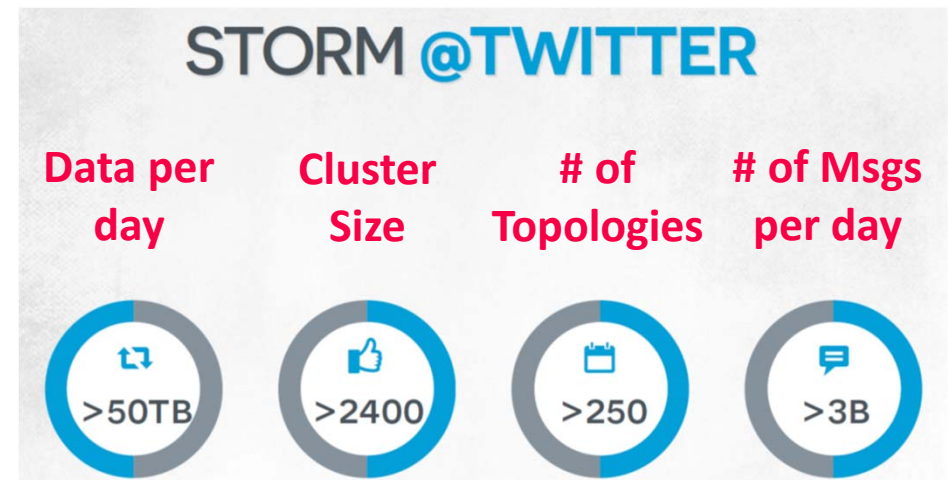

■ Twitter Heron

- API-compatible distributed streaming engine
- **De-facto streaming engine at Twitter** since 2014

[Sanjeev Kulkarni et al:
Twitter Heron: Stream
Processing at Scale.
SIGMOD 2015]



■ Dhalion (Heron Extension)

- Automatically reconfigure Heron topologies to meet throughput SLO

[Avrilia Floratou et al:
Dhalion: Self-Regulating
Stream Processing in Heron.
PVLDB 2017]



- Now back pressure implemented in Apache Storm 2.0 (May 2019)

Distributed Stream Processing

Query-Aware Stream Partitioning

Example Use Case

- **AT&T network monitoring** with Gigascope (e.g., OC768 network)
- 2x40 Gbit/s traffic → 112M packets/s → **26 cycles/tuple** on 3Ghz CPU
- Complex query sets (apps w/ **~50 queries**) and massive data rates

[Theodore Johnson, S. Muthu Muthukrishnan, Vladislav Shkapenyuk, Oliver Spatscheck: Query-aware partitioning for monitoring massive network data streams. **SIGMOD 2008**]



Baseline Query Execution Plan

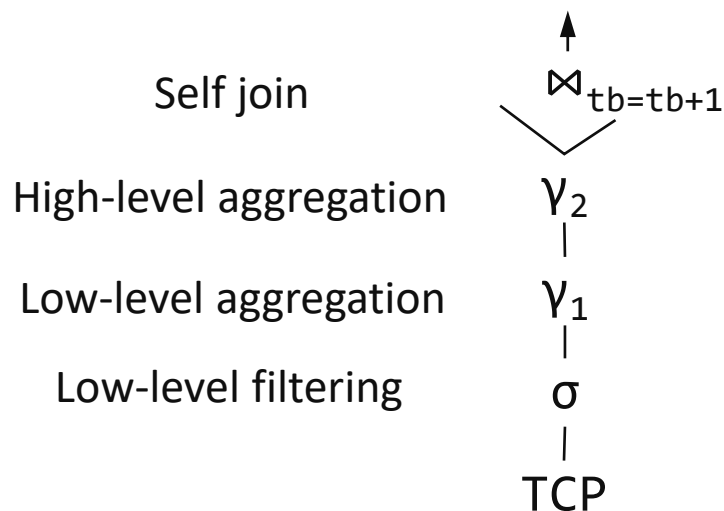

Query **flow_pairs**:

```
SELECT S1.tb, S1.srcIP, S1.max, S2.max
FROM heavy_flows S1, heavy_flows S2
WHERE S1.srcIP = S2.srcIP
and S1.tb = S2.tb+1
```

Query **heavy_flows**:

```
SELECT tb,srcIP,max(cnt) as max_cnt
FROM flows
GROUP BY tb, srcIP
```

Query **flows**:

```
SELECT tb, srcIP, destIP, COUNT(*) AS cnt
FROM TCP WHERE ...
GROUP BY time/60 AS tb,srcIP,destIP
```

Query-Aware Stream Partitioning, cont.

- **Optimized Query Execution Plan**
 - Distributed plan operators
 - Pipeline and task parallelism

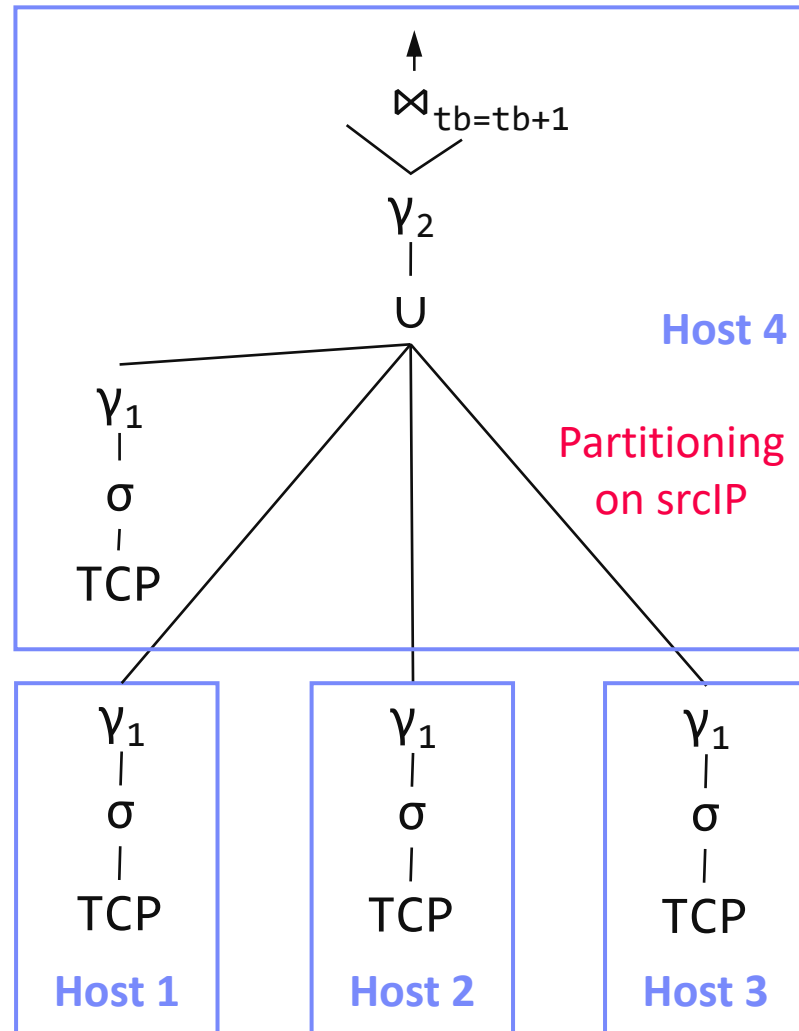
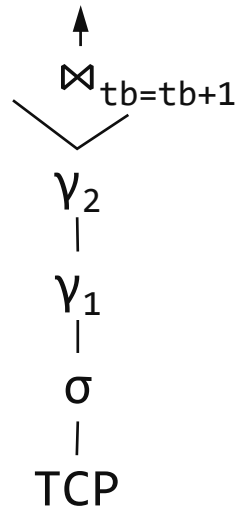

Stream Group Partitioning

11 Distributed, Data-Parallel Computation

- **Large-Scale Stream Processing**
 - Limited pipeline parallelism and task parallelism (independent subqueries)
 - Combine with **data-parallelism over stream groups**

- **#1 Shuffle Grouping**

- Tuples are randomly distributed across consumer tasks
- Good load balance

- **#2 Fields Grouping**

- Tuples partitioned by grouping attributes
- Guarantees order within keys, but load imbalance if skew

- **#3 Partial Key Grouping**

- Apply **“power of two choices”** to streaming
- **Key splitting**: select among 2 candidates per key (works for all associative aggregation functions)

- **#4 Others: Global, None, Direct, Local**

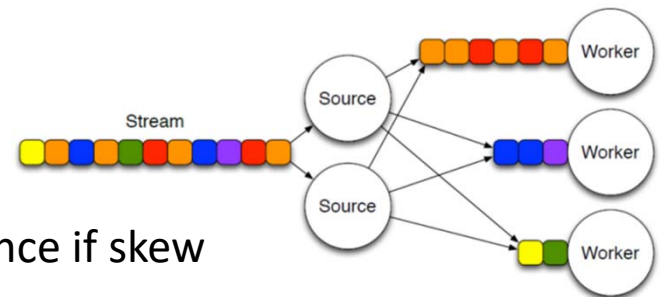

[Md Anis Uddin Nasir et al:
The power of both choices:
Practical load balancing for
distributed stream processing
engines. **ICDE 2015**]



Example Apache Storm



Example Topology DAG

- **Spouts:** sources of streams
- **Bolts:** UDF compute ops
- Tasks mapped to worker processes and executors (threads)

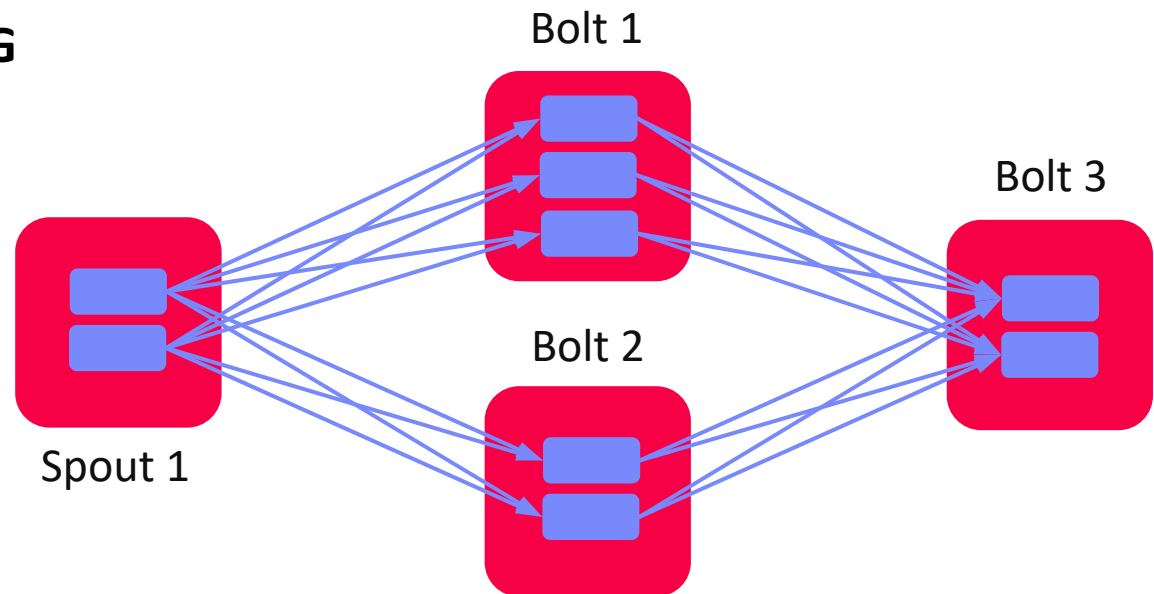

```
Config conf = new Config();  
conf.setNumWorkers(3);
```

```
topBuilder.setSpout("Spout1", new FooS1(), 2);  
topBuilder.setBolt("Bolt1", new FooB1(), 3).shuffleGrouping("Spout1");  
topBuilder.setBolt("Bolt2", new FooB2(), 2).shuffleGrouping("Spout1");  
topBuilder.setBolt("Bolt3", new FooB3(), 2)  
    .shuffleGrouping("Bolt1").shuffleGrouping("Bolt2");
```

```
StormSubmitter.submitTopology(..., topBuilder.createTopology());
```

Example Twitter Heron

[Credit: Karthik Ramasamy]

■ Motivation

- Heavy use of Apache Storm at Twitter
- Issues: **debugging**, **performance**, shared **cluster resources**, back pressure mechanism

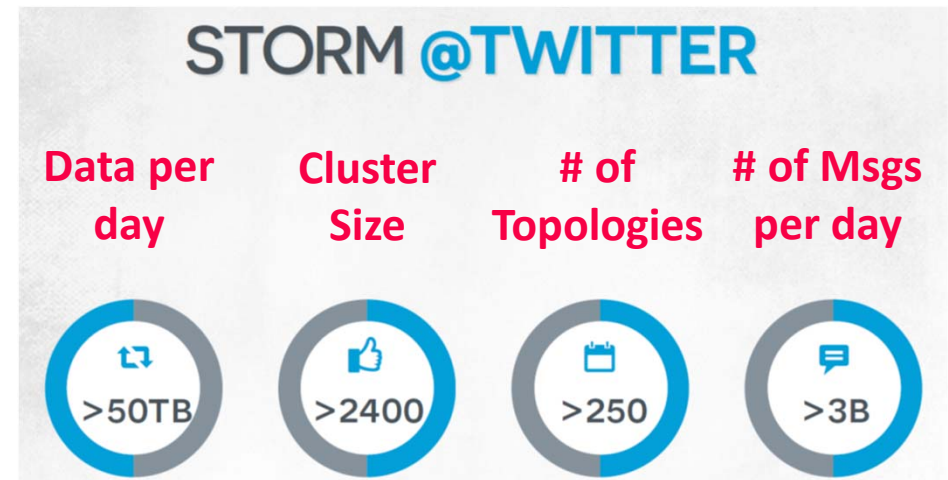

■ Twitter Heron

- API-compatible distributed streaming engine
- **De-facto streaming engine at Twitter** since 2014

[Sanjeev Kulkarni et al:
Twitter Heron: Stream
Processing at Scale.
SIGMOD 2015]



■ Dhalion (Heron Extension)

- Automatically reconfigure Heron topologies to meet throughput SLO

[Avrilia Floratou et al:
Dhalion: Self-Regulating
Stream Processing in Heron.
PVLDB 2017]



- Now back pressure implemented in Apache Storm 2.0 (May 2019)

Discretized Stream (Batch) Computation



■ Motivation

- **Fault tolerance** (low overhead, fast recovery)
- Combination w/ **distributed batch analytics**

[Matei Zaharia et al: Discretized streams: fault-tolerant streaming computation at scale. **SOSP 2013**]



■ Discretized Streams (DStream)

- **Batching of input tuples** (100ms – 1s) based on ingest time
- Periodically run distributed jobs of **stateless, deterministic tasks** → **DStreams**
- State of all tasks materialized as RDDs, recovery via lineage

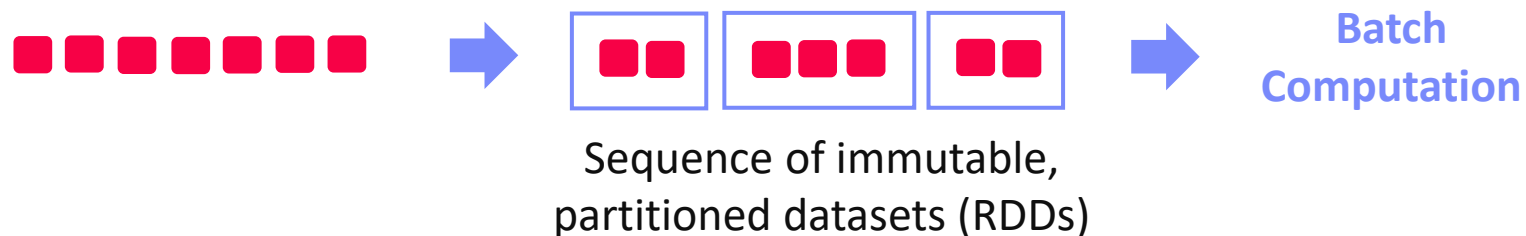

- **Criticism: High latency, required for batching**

Unified Batch/Streaming Engines

■ Apache Spark Streaming (Databricks)

- **Micro-batch computation** with exactly-once guarantee
- Back-pressure and water mark mechanisms
- **Structured streaming** via SQL (2.0), **continuous streaming** (2.3)



■ Apache Flink (Data Artisans, now Alibaba)

- **Tuple-at-a-time** with exactly-once guarantee
- Back-pressure and water mark mechanisms
- Batch processing viewed as special case of streaming



[<https://flink.apache.org/news/2019/02/13/unified-batch-streaming-blink.html>]

■ Google Cloud Dataflow

- **Tuple-at-a-time** with exactly-once guarantee
- MR → FlumeJava → MillWheel → Dataflow
- Google's fully managed batch and stream service

[T. Akidau et al.: The Dataflow Model: A Practical Approach to Balancing Correctness, Latency, and Cost in Massive-Scale, Unbounded, Out-of-Order Data Processing. **PVLDB 2015**]



➔ Apache Beam (API+SDK from Dataflow)

- **Abstraction for Spark, Flink, Dataflow** w/ common API, etc
- Individual runners for the different runtime frameworks



Resource Elasticity

[Li Wang, Tom Z. J. Fu, Richard T. B. Ma, Marianne Winslett, Zhenjie Zhang: Elasticutor: Rapid Elasticity for Realtime Stateful Stream Processing. **SIGMOD 2019**]



- **#1 Static**
 - Static, operator-level key partitioning

- **#2 Resource-Centric**
 - Dynamic, operator-level key partitioning
 - **Global synchronization** for key repartitioning and state migration

- **#3 Executor-Centric**
 - Static, operator-level key partitioning
 - **CPU core reassignments** via local and remote tasks

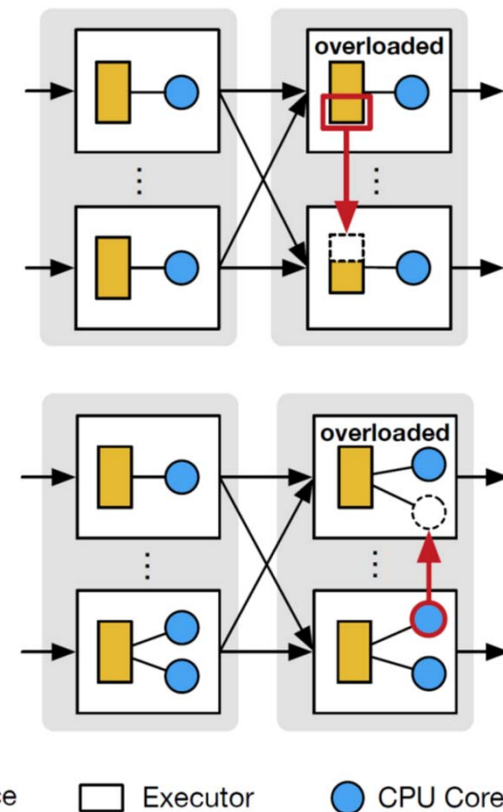

Data Stream Mining

Selected Example Algorithms

Overview Stream Mining

■ Streaming Analysis Model

- Independent of actual storage model and processing system
- Unbounded stream of data item $S = (s_1, s_2, \dots)$
- Evaluate function $f(S)$ as aggregate over stream or window of stream
- Standing vs ad-hoc queries

■ Recap: Classification of Aggregates

02 Data Warehousing,
ETL, and SQL/OLAP

- **Additive** aggregation functions (**SUM**, **COUNT**)
- **Semi-additive** aggregation functions (**MIN**, **MAX**)
- **Additively computable** aggregation functions (**AVG**, **STDDEV**, **VAR**)
- ~~Aggregation functions (**MEDIAN**, **QUANTILES**)~~ → approximations

➔ Selected Algorithms

- Higher-Order Statistics (e.g., **STDDEV**)
- Approximate # Distinct Items (e.g., KMV, HyperLogLog)
- Approximate Heavy Hitters (e.g. CountMin-Sketch)

Higher-Order Statistics

Overview Order Statistics

- Many order statistics computable via **p^{th} central moment**
- Examples:** Variance σ^2 , skewness, kurtosis

$$m_p = \frac{1}{n} \sum_{i=1}^n (x_i - \bar{x})^p$$

Incremental Computation of Variance

- #1 Default 2-pass algorithm** (mean, and squared diffs)
- #2 Textbook 1-pass algorithm** (incrementally maintainable)
→ **numerically instable**
- #3 Incremental update rules for m_p** with **Kahan addition** (variance since 1979)

$$\sigma^2 = \frac{n}{n-1} m_2$$

$$\frac{1}{n} \sum_{i=1}^n x_i^2 - \frac{1}{n^2} \left(\sum_{i=1}^n x_i \right)^2$$

$$n = n_a + n_b, \quad \delta = \mu_b - \mu_a, \quad \mu = \mu_a \oplus n_b \frac{\delta}{n}$$

$$M_p = M_{p,a} \oplus M_{p,b} \oplus \left\{ \sum_{j=1}^{p-2} \binom{p}{j} \left[\left(-\frac{n_b}{n} \right)^j M_{p-j,a} + \left(\frac{n_a}{n} \right)^j M_{p-j,b} \right] \delta^j + \left(\frac{n_a n_b}{n} \delta \right)^p \left[\frac{1}{n_b^{p-1}} - \left(\frac{-1}{n_a} \right)^{p-1} \right] \right\}$$



[Yuanyuan Tian, Shirish Tatikonda, Berthold Reinwald: Scalable and Numerically Stable Descriptive Statistics in **SystemML**. ICDE 2012]

11 Distributed, Data-Parallel Computation

Number of Distinct Items

Problem

- Estimate # distinct items in a dataset / data stream w/ limited memory
- Support for set operations (union, intersect, difference)

K-Minimum Values (KMV)

- Hash values d_i to $h_i \in [0, M]$
- Domain $M = O(D^2)$ to avoid collisions $\rightarrow O(k \log D)$ space
- Store k minimum hash values (e.g., via priority queue) in normalized form $h_i \in [0, 1]$
- Basic estimator:
- Unbiased estimator:

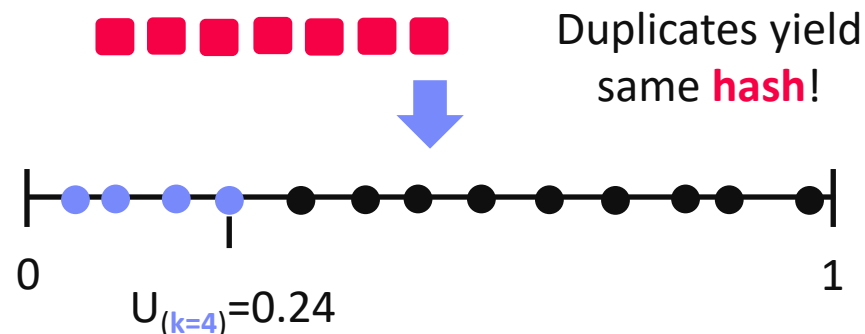

$$\hat{D}_k^{BE} = k/U_{(k)}$$

$$\hat{D}_k^{UB} = (k - 1)/U_{(k)}$$

Example:
16.67 vs 12.5



[Kevin S. Beyer, Peter J. Haas, Berthold Reinwald, **Yannis Sismanis**, Rainer Gemulla: On synopses for distinct-value estimation under multiset operations. **SIGMOD 2007**]

Number of Distinct Items, cont

■ KMV Set Operations

- Union and intersection directly on partition synopses
- Difference via **Augmented KMV** (AKMV) that include counters of multiplicities of k-minimum values

11 Distributed, Data-Parallel Computation

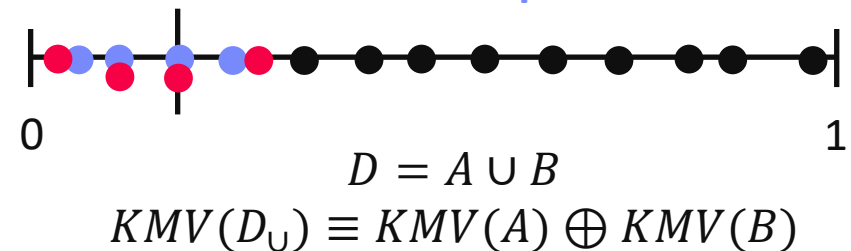

■ HyperLogLog

- Hash values and maintain maximum **# of leading zeros** $p \rightarrow \hat{D} = 2^p$
- Stochastic averaging over m sub-streams (p maintain in registers M)
- **HyperLogLog++**

[P. Flajolet, Éric Fusy, O. Gandouet, and F. Meunier: Hyperloglog: The analysis of a near-optimal cardinality estimation algorithm. **AOFA 2007**]



[Stefan Heule, Marc Nunkesser, Alexander Hall: HyperLogLog in practice: algorithmic engineering of a state of the art cardinality estimation algorithm. **EDBT 2013**]



Stream Summarization

[Graham Cormode, S. Muthukrishnan:
An Improved Data Stream Summary:
The **Count-Min Sketch** and Its
Applications. LATIN 2004]



■ Problem

- **Summarize stream in sketch**/synopsis w/ limited memory
- Finding quantiles, frequent items (heavy hitters), etc

■ Count-Min (CM) Sketch

- Two-dimensional count array of width w and depth d
- d hash functions map $\{1 \dots n\} \rightarrow \{1 \dots w\}$
- **Update** (s_i, c_i): compute d hashes for s_i and increase counts of all locations
- **Point query** (s_i): compute d hashes for s_i and estimate frequency as $\min(\text{count}[j, h_j(s_i)])$



Unlikely similar
hash collisions

h_1		6			2	1
h_2	1		3	5		
h_3	3		4		1	1
h_4		1	2	1	5	
h_d		7	1	1		

Summary and Q&A

- **Data Stream Processing**
- **Distributed Stream Processing**
- **Data Stream Mining**

- **Projects and Exercises**
 - **13 projects + 3 exercises** → grace period: **end of Feb**
 - In case of problem: ask for help + problem scaling possible

- **Next Lectures**
 - **13 Distributed Machine Learning Systems** [Jan 31]
 - **Oral Exams** [Feb 3 - Feb 5] (11 participants?)

Note: 706.550
Architecture of Machine Learning Systems (AMLS)